

## A01-A

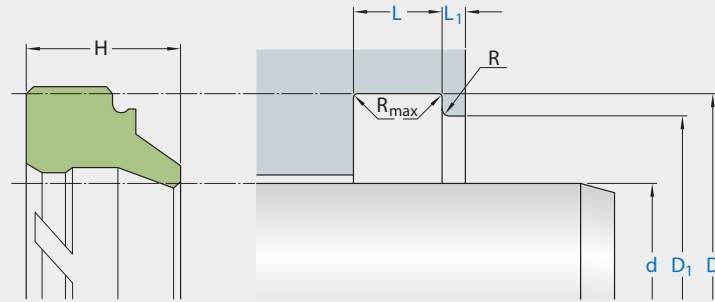

Ordering dimensions in blue

Surface roughness	$R_{tmax}$	$R_a$
Sliding surface	$\leq 2,5 \mu m$	$0,05-0,3 \mu m$
Bottom of groove	$\leq 6,3 \mu m$	$\leq 1,6 \mu m$
Groove face	$\leq 15 \mu m$	$\leq 3 \mu m$

Bearing area: 50–95% and a cutting depth of  $0,5 R_z$ , based on  $C_{ref} = 0\%$

Standard dimensions		D	D <sub>1</sub>	L	L <sub>1</sub>	R <sub>max</sub>	R	H
d	f8	H11	H11	+0,2				
over	incl.							
mm								
11	100	d + 8	d + 6	4	1	0,4	$\leq 0,4$	7
100	150	d + 12	d + 9	5,5	1,5	0,4	$\leq 0,4$	10
150		d + 15	d + 11	6,5	2	0,4	$\leq 0,4$	13

### application



*not bolded symbols; please consult our technical for application limitations*

## operating parameters & material

diameter range: up to 600 mm

material	temperature	max. surface speed	hydrolysis	dry running	wear resistance
ECOPUR	-30 °C ... +110 °C	4 m/s	-	+	++
H-ECOPUR	-20 °C ... +110 °C	4 m/s	++	+	++
T-ECOPUR	-50 °C ... +110 °C	4 m/s	-	+	++
S-ECOPUR	-20 °C ... +110 °C	5 m/s	++	++	++
G-ECOPUR	-30 °C ... +110 °C	4 m/s	++	+	++
Ecorubber 1	-30 °C ... +100 °C	4 m/s	-	-	O
Ecorubber 2	-20 °C ... +200 °C	4 m/s	-	-	O
Ecorubber 3 <sup>2</sup>	-50 °C ... +150 °C	4 m/s	++	-	O
Ecorubber H	-25 °C ... +150 °C	4 m/s	+	O	+
X-ECOPUR	-30 °C ... +110 °C	4 m/s			
XH-ECOPUR	-20 °C ... +110 °C	4 m/s			
XS-ECOPUR	-20 °C ... +110 °C	5 m/s			

the stated operation conditions represent general indications. it is recommended not to use all maximum values simultaneously. surface speed limits apply only to the presence of adequate lubrication film.

<sup>2</sup> attention: not suitable for mineral oils!

++ ... particularly suitable

o ... conditional suitable

+ ... suitable

- ... not suitable

for detailed information regarding chemical resistance please refer to our "list of resistance". for increased chemical and thermal resistance rubber materials are to be preferred, polyurethan materials increase wear resistance.

## surface quality

surface roughness	Rtmax (µm)	Ra (µm)
sliding surface	according to seal data	
bottom of groove	≤6,3	≤1,6
groove face	≤15	≤3

## tolerance recommendation

seal housing tolerances		cs	R [mm]
L < 10 mm	0,2	≤ 5	max. 0,3
L ≥ 10 mm	0,3	>5.....≤ 7,5	max. 0,4
D1	H11	>7,5.....≤ 10	max. 0,6
D	H11	> 10	max. 0,8

the L1 measurement, which is dependent on the height of the wiper, is selected as follows:

H [mm]	L1 [mm]
≤ 7	1
10	1,5
13	2

## mode of installation

the prerequisites for perfect functioning are careful fitting and an accurately dimensioned mounting space. in general, wipers snap easily into their housings when distorted into a kidney shape (over 20mm diameter). when mounted in cylinders that cannot be dismantled, the rings can also be cut open. in such cases, an approx. 2-3% larger diameter should be chosen.

when the wiper is installed, the two ends are snapped into place first, and then the entire ring is pressed in along the entire circumference. no gluing of the joining ends is required.