

S16-B

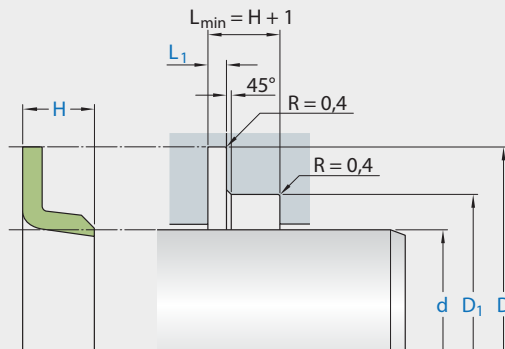

Ordering dimensions in **blue**

Surface roughness	R_{tmax}	R_a
Sliding surface	$\leq 2,5 \mu m$	$0,05-0,3 \mu m$
Bottom of groove	$\leq 6,3 \mu m$	$\leq 1,6 \mu m$
Groove face	$\leq 15 \mu m$	$\leq 3 \mu m$

Bearing area: 50–95% and a cutting depth of $0,5 R_z$, based on $C_{ref} = 0\%$

Standard dimensions

Minimum nominal inside diameter
 $d \geq 11 \text{ mm}$.

This is not a standard profile and serves as a replacement for an existing installation space. New constructions should use standard profiles.

application



not bolded symbols; please consult our technical for application limitations

operating parameters & material

diameter range: up to 600 mm

material	temperature	max. surface speed	max. pressure ¹	hydrolysis	dry running	wear resistance
ECOPUR	-30 °C ... +110 °C	0,5 m/s	160 bar (16 MPa)	-	+	++
H-ECOPUR	-20 °C ... +110 °C	0,5 m/s	160 bar (16 MPa)	++	+	++
T-ECOPUR	-50 °C ... +110 °C	0,5 m/s	160 bar (16 MPa)	-	+	++
S-ECOPUR	-20 °C ... +110 °C	0,7 m/s	160 bar (16 MPa)	++	++	++
Ecorubber 1	-30 °C ... +100 °C	0,5 m/s	160 bar (16 MPa)	-	-	O
Ecorubber 2	-20 °C ... +200 °C	0,5 m/s	160 bar (16 MPa)	-	-	O
Ecorubber 3 ²	-50 °C ... +150 °C	0,5 m/s	160 bar (16 MPa)	++	-	O
Ecorubber H	-25 °C ... +150 °C	0,5 m/s	160 bar (16 MPa)	+	O	+

the stated operation conditions represent general indications. it is recommended not to use all maximum values simultaneously.

surface speed limits apply only to the presence of adequate lubrication film.

¹ pressure ratings are dependent on the size of the extrusion gap.

++ ... particularly suitable

o ... conditional suitable

+ ... suitable

- ... not suitable

for detailed information regarding chemical resistance please refer to our „list of resistance“. for increased chemical and thermal resistance rubber materials are to be preferred, polyurethan materials increase wear resistance. for higher gliding speeds another system should be used (e.g. PTFE materials)

mode of installation

special shaped, open housings are required. the axial compression of the flange should not exceed 5 to 10% of the height, a clamping torque limitation should be arranged. to avoid twisting in the sealing lip, the compression should occur only at the clamp flange.

recommended mounting space:

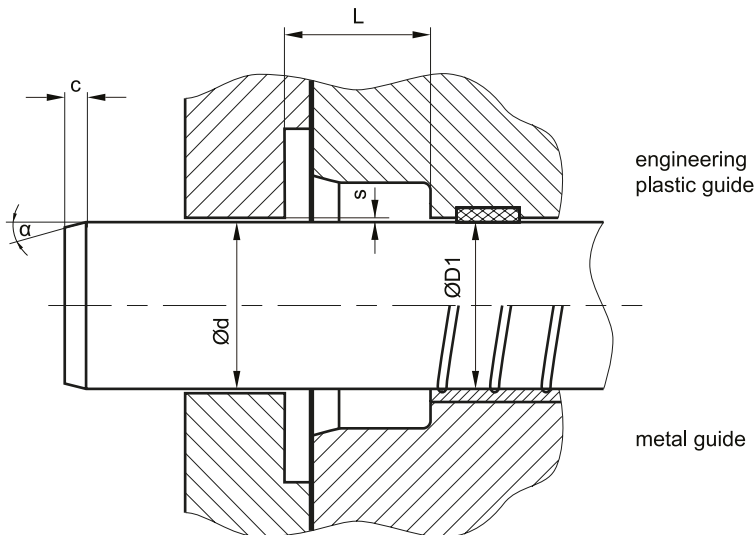

recommended guide tolerance D1:

d f8 [mm]	p ≤ 100 [bar]	p > 100 [bar]
≤ 100	H10	H8
> 100 ≤ 200	H10	H8
> 200	H9	H8

insertion chamfer:

in order to avoid damage to the rod seal during installation, the piston rod is to be chamfered and rounded as shown in the "recommended mounting space" drawing. the size of chamfer depends on the seal type and profile width.

cs (mm)	c (mm)	
	α = 15° ... 20°	α = 20° ... 30°
4	3,5	2
5	4	2,5
6	4,5	3
7,5	5	4
10	6	5
12,5	8,5	6,5
15	10	7,5
20	13	10