

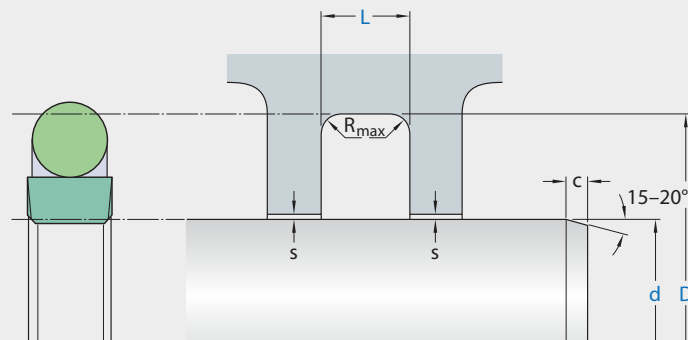

## S09-D



Ordering dimensions in blue

Surface roughness	$R_{tmax}$	$R_a$
Sliding surface	$\leq 2,5 \mu m$	$0,05-0,3 \mu m$
Bottom of groove	$\leq 6,3 \mu m$	$\leq 1,6 \mu m$
Groove face	$\leq 15 \mu m$	$\leq 3 \mu m$

Bearing area: 50-95% and a cutting depth of  $0,5 R_z$ , based on  $C_{ref} = 0\%$

Standard dimensions		D H10	L $+0,2$	$R_{max}$	c	OD	Maximal radial extrusion gap $s^*$			
d f8 over	incl.						100 bar	200 bar	400 bar	600 bar
mm							mm			
4	8	$d + 4,9$	2,2	0,4	2,5	1,78	0,30	0,30	0,20	0,10
8	19	$d + 7,3$	3,2	0,6	3,5	2,62	0,40	0,30	0,20	0,10
19	38	$d + 10,7$	4,2	1,0	4,5	3,53	0,50	0,40	0,30	0,20
38	200	$d + 15,1$	6,3	1,3	5,0	5,33	0,50	0,40	0,30	0,20
200	256	$d + 20,5$	8,1	1,8	6,0	7,00	0,70	0,50	0,40	0,20
256	650	$d + 24,0$	8,1	1,8	8,0	7,00	0,70	0,50	0,40	0,20
650	1 000	$d + 27,3$	9,5	2,5	10,0	8,40	0,80	0,70	0,50	0,30
1 000	3 000	$d + 38,0$	13,8	3,0	12,0	12,00	1,10	0,80	0,70	0,40

### application



*not bolded symbols; please consult our technical for application limitations*

\* Extrusion gap values shown above are valid for a temperature of 80 °C, higher temperatures require lower values.

## operating parameters & material

diameter range: up to 600 mm

material		temperature	max. surface speed	max. pressure <sup>1</sup>	hydrolysis	dry running	wear resistance
sealing element	energizer						
Ecoflon 2	Ecorubber 1	-30 °C ... +100 °C	10 m/s		-	++	+
Ecoflon 3	Ecorubber 1	-30 °C ... +100 °C	10 m/s		-	++	+
Ecoflon 4	Ecorubber 1	-30 °C ... +100 °C	10 m/s		-	++	+
Ecoflon 2	Ecorubber 2	-20 °C ... +200 °C	10 m/s		-	++	+
Ecoflon 3	Ecorubber 2	-20 °C ... +200 °C	10 m/s		-	++	+
Ecoflon 4	Ecorubber 2	-20 °C ... +200 °C	10 m/s	400 bar (40 MPa)	-	++	+
Ecoflon 2	Ecorubber 3 <sup>2</sup>	-50 °C ... +150 °C	10 m/s	800 bar (80 MPa) <sup>3</sup>	++	++	+
Ecoflon 3	Ecorubber 3 <sup>2</sup>	-50 °C ... +150 °C	10 m/s		++	++	+
Ecoflon 4	Ecorubber 3 <sup>2</sup>	-50 °C ... +150 °C	10 m/s		++	++	+
Ecoflon 2	Ecosil	-60 °C ... +200 °C	10 m/s		++	++	+
Ecoflon 3	Ecosil	-60 °C ... +200 °C	10 m/s		++	++	+
Ecoflon 4	Ecosil	-60 °C ... +200 °C	10 m/s		++	++	+
Ecowear	Ecosil	-60 °C ... +80 °C	10 m/s	400 bar (40 MPa)	++	+	+
X-ECOPUR	Ecorubber 1	-30 °C ... +110 °C	5 m/s	600 bar (40 MPa)			

the stated operation conditions represent general indications. it is recommended not to use all maximum values simultaneously. surface speed limits apply only to the presence of adequate lubrication film.

<sup>1</sup> pressure ratings are dependent on the size of the extrusion gap.

<sup>2</sup> attention: not suitable for mineral oils!

<sup>3</sup> only in special cases (small extrusion gap, low surface speed)

++ ... particularly suitable                      o ... conditional suitable

+ ... suitable    - ... not suitable

for detailed information regarding chemical resistance please refer to our "list of resistance". for decreased leakage rates elastomer materials (polyurethane or rubber) in other sealing systems are to be preferred.

note on special materials:

as temperature limit and chemical resistance are determined by the preload element, the temperature range can be increased and the resistance to chemical influences improved, if a special material is used for the preload element.

### mode of installation

for inside diameters of 25 mm or more, and dependant on radial cross section (cs), seals may be snapped into a closed housing.

Ød	type of installation
≤ 6•cs	open mounting space required
> 6•cs ..... ≤ 10•cs	snap mounting with tool
> 10•cs	snap mounting by hand

### recommended mounting space:

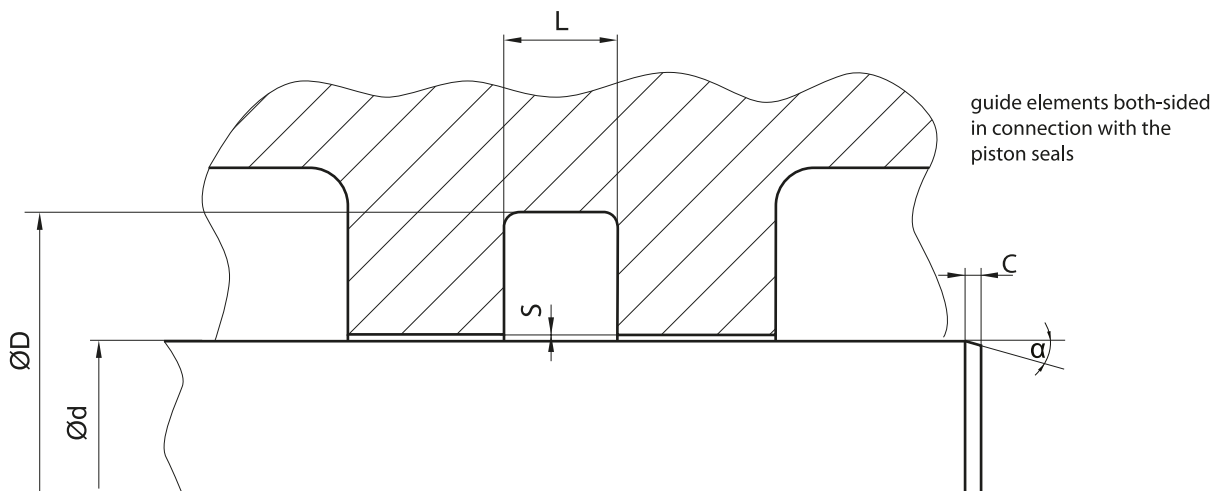

**recommended guide tolerance D1:**

in most cases the guiding elements are integrated in the piston seal system on both sides. if not use below recommendations for D1 (=inside diameter of the guiding elements):

d f8 [mm]	p ≤ 100 [bar]	100 < p ≤ 200 [bar]	p > 200 [bar]
≤ 100	H10	H8	H8
> 100 ≤ 200	H10	H8	H7
>200	H9	H8	H7

**insertion chamfer:**

in order to avoid damage to the rod seal during installation, the piston rod is to be chamfered and rounded as shown in the "recommended mounting space" drawing. the size of chamfer depends on the seal type and profile width.

cs (mm)	c (mm)	
	α = 15° ... 20°	α = 20° ... 30°
2,45	2,5	1,5
3,5	3,5	2
5,35	4,5	3
7,55	5	3,5
10,25	6	5
12	8	6
13,65	10	7