

K17-P

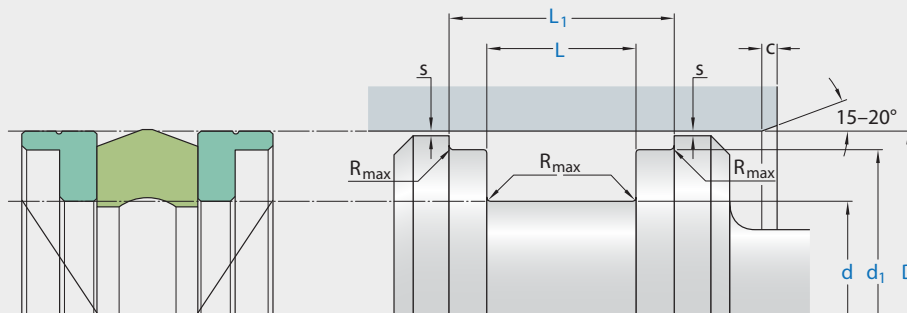

Ordering dimensions in blue

| Surface roughness | R_{tmax} | R_a |
|-------------------|------------------|------------------|
| Sliding surface | $\leq 2,5 \mu m$ | $0,05-0,2 \mu m$ |
| Bottom of groove | $\leq 6,3 \mu m$ | $\leq 1,6 \mu m$ |
| Groove face | $\leq 15 \mu m$ | $\leq 3 \mu m$ |

Bearing area: 50-95% and a cutting depth of $0,5 R_z$, based on $C_{ref} = 0\%$

| Standard dimensions | | | | | | | | |
|---------------------|-------|------|----------------|------|----------------|------------------|-----|------|
| D | H9 | d | d ₁ | L | L ₁ | R _{max} | c | s* |
| over | incl. | h9 | h8 | +0,2 | | | | |
| mm | | | | | | | | |
| 13 | 40 | D-8 | D-3 | 10 | 18 | 0,4 | 4 | 0,35 |
| 40 | 80 | D-10 | D-3 | 10 | 18 | 0,4 | 4 | 0,40 |
| 80 | 120 | D-15 | D-4 | 15 | 23 | 0,4 | 5 | 0,50 |
| 120 | 200 | D-20 | D-5 | 20 | 33 | 0,4 | 6 | 0,65 |
| 200 | 400 | D-25 | D-6 | 25 | 39 | 0,4 | 8,5 | 0,75 |
| 400 | 600 | D-30 | D-8 | 30 | 44 | 0,4 | 10 | 1,00 |

* Extrusion gap values shown above are valid for a temperature of 70 °C, higher temperatures require lower values.

application



not bolded symbols; please consult our technical for application limitations

operating parameters & material

diameter range: up to 600 mm

| material | | temperature | max. surface speed | max. pressure ¹ | hydrolysis | dry running | wear resistance |
|-----------------|----------------------------|--------------------|--------------------|----------------------------|------------|-------------|-----------------|
| sealing element | back-up ring | | | | | | |
| ECOPUR | Ecotal/Ecomid ² | -30 °C ... +100 °C | 0,5 m/s | 250 bar (25 MPa) | - | + | + |
| H-ECOPUR | Ecotal/Ecomid ² | -20 °C ... +100 °C | 0,5 m/s | 250 bar (25 MPa) | + | + | + |
| S-ECOPUR | Ecotal/Ecomid ² | -40 °C ... +100 °C | 0,5 m/s | 250 bar (25 MPa) | - | + | + |
| T-ECOPUR | Ecotal/Ecomid ² | -20 °C ... +100 °C | 0,7 m/s | 250 bar (25 MPa) | + | ++ | + |
| G-ECOPUR | Ecotal/Ecomid ² | -30 °C ... +100 °C | 0,5 m/s | 250 bar (25 MPa) | + | + | + |

the stated operation conditions represent general indications. it is recommended not to use all maximum values simultaneously.

surface speed limits apply only to the presence of adequate lubrication film.

¹ pressure ratings are dependent on the size of the extrusion gap.

² Ecotal up to ø260 mm, Ecomid above ø260 mm.

++ ... particularly suitable

o ... conditional suitable

+ ... suitable

- ... not suitable

for detailed information regarding chemical resistance please refer to our „list of resistance“. for increased chemical and thermal resistance rubber materials are to be preferred, attention should be paid to restrictions for pressure range and wear resistance. for higher gliding speeds another system should be used (e.g. PTFE materials).

note on special materials:

the temperature limits are determined by the guide- and support parts, using special materials can expand the temperature limits.

mode of installation

the first guiding- and backup element should be placed into the groove, then the sealing element should be slipped over the piston and snapped into the groove, then the second guiding- and backup element should be placed into the groove. for inside diameters of 40mm and more, the seal can generally be slipped over the piston and snapped into closed grooves. due to occurring deformation force at installation, assembly aid tools are to be used for large cross-sections. the material deformation should not exceed the value of 20%, otherwise the permanent deformation would be too large.

recommended mounting space:

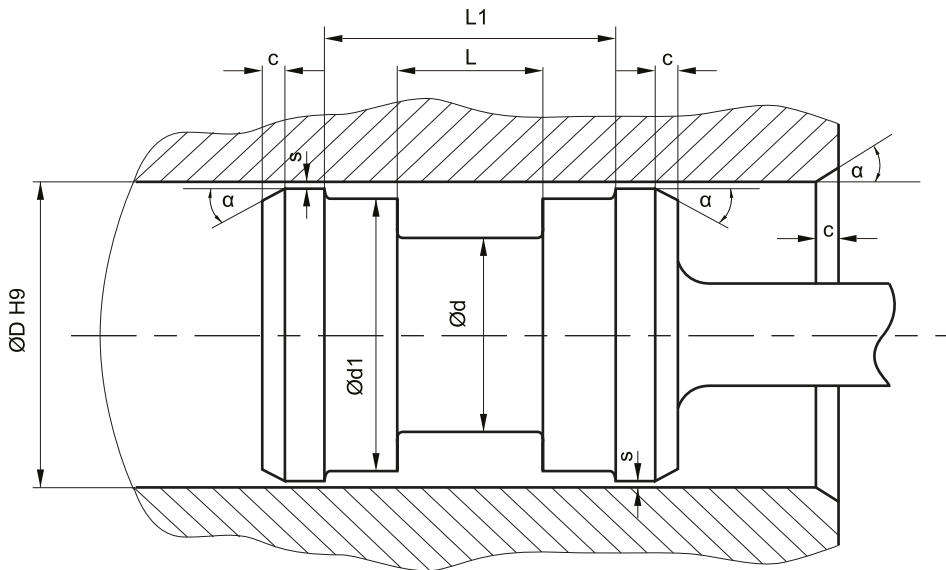

insertion chamfer:

in order to avoid damage to the piston seal during installation, the piston and the housing is to be chamfered and rounded as shown in the "recommended mounting space" drawing. the size of chamfer depends on the seal type and profile width.

| cs (mm) | c (mm) | |
|---------|-----------------|-----------------|
| | α = 15° ... 20° | α = 20° ... 30° |
| 5 | 4 | 2,5 |
| 7,5 | 5 | 4 |
| 10 | 6 | 5 |
| 12,5 | 8,5 | 6,5 |
| 15 | 10 | 7,5 |
| 20 | 13 | 10 |

instead of a chamfer, the piston can also be designed with a radius. recommended size of the radius is equal to size of chamfer (R=c).