

## K16-B

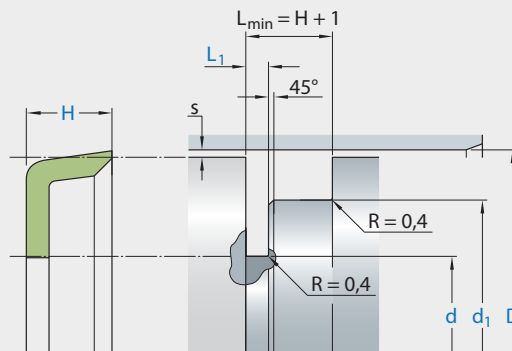

Ordering dimensions in blue

Surface roughness	$R_{tmax}$	$R_a$
Sliding surface	$\leq 2,5 \mu m$	0,05–0,2 $\mu m$
Bottom of groove	$\leq 6,3 \mu m$	$\leq 1,6 \mu m$
Groove face	$\leq 15 \mu m$	$\leq 3 \mu m$

Bearing area: 50–95% and a cutting depth of  $0,5 R_z$ , based on  $C_{ref} = 0\%$

### Standard dimensions

This is not a standard profile and serves as a replacement for an existing housing. New constructions should use standard profiles.

### application



not bolded symbols; please consult our technical for application limitations

## operating parameters & material

diameter range: up to 600 mm

material	temperature	max. surface speed	max. pressure <sup>1</sup>	hydrolysis	dry running	wear resistance
ECOPUR	-30 °C ... +110 °C	0,5 m/s	160 bar (16 MPa)	+	+	++
H-ECOPUR	-20 °C ... +110 °C	0,5 m/s	160 bar (16 MPa)	++	+	++
G-ECOPUR	-30 °C ... +110 °C	0,5 m/s	160 bar (16 MPa)			
T-ECOPUR	-50 °C ... +110 °C	0,5 m/s	160 bar (16 MPa)	-	+	++
S-ECOPUR	-20 °C ... +110 °C	0,7 m/s	160 bar (16 MPa)	++	++	++
Ecorubber 1	-30 °C ... +100 °C	0,5 m/s	160 bar (16 MPa)	-	-	O
Ecorubber 2	-20 °C ... +200 °C	0,5 m/s	160 bar (16 MPa)	-	-	O
Ecorubber 3 <sup>2</sup>	-50 °C ... +150 °C	0,5 m/s	160 bar (16 MPa)	++	-	O
Ecorubber H	-25 °C ... +150 °C	0,5 m/s	160 bar (16 MPa)	+	O	+

the stated operation conditions represent general indications. it is recommended not to use all maximum values simultaneously. surface speed limits apply only to the presence of adequate lubrication film.

<sup>1</sup> pressure ratings are dependent on the size of the extrusion gap.

<sup>2</sup> attention: not suitable for mineral oils!

++ ... particularly suitable

o ... conditional suitable

+ ... suitable

- ... not suitable

for detailed information regarding chemical resistance please refer to our „list of resistance“. for increased chemical and thermal resistance rubber materials are to be preferred, Polyurethan materials increase wear resistance. for higher gliding speeds another system should be used (e.g. PTFE materials).

### mode of installation

special shaped, open housings are required. the axial compression of the flange should not exceed 5 to 10% of the height , a clamping torque limitation should be arranged. to avoid twisting in the sealing lip, the compression should occur only at the clamp flange.

### recommended mounting space:

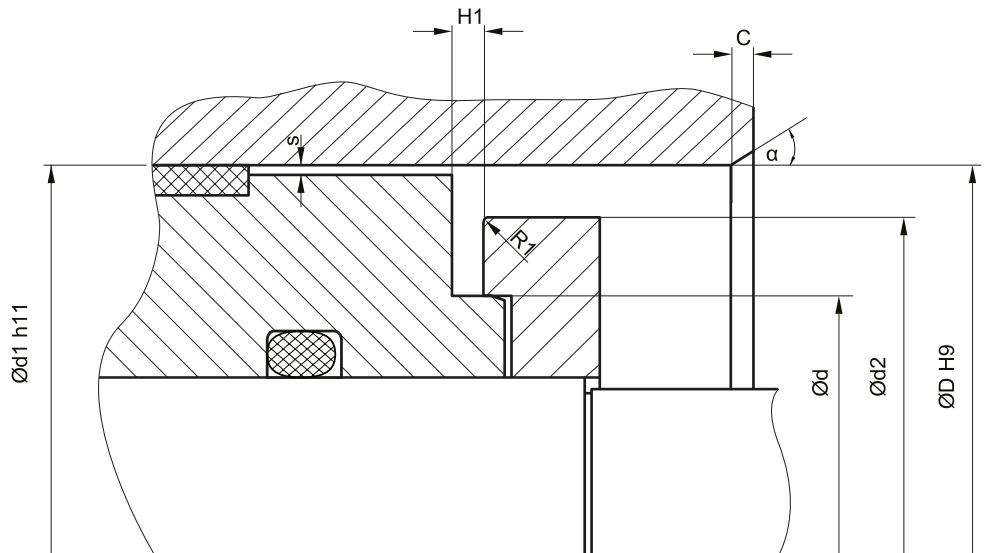

plastic guiderings (wearbands) have to feature a adequate cutting gap (recommendation: 2-5% of D). if metallic guides are used, spiral grooves shall be provided.

in order to avoid drag pressure built up in case of back-to-back arrangement, the distance between the seals should be as small as possible.

radius R1 should be at least equal to the radius at the seal.

### insertion chamfer:

in order to avoid damage to the piston seal during installation, the piston and the housing is to be chamfered and rounded as shown in the "recommended mounting space" drawing. the size of chamfer depends on the seal type and profile width.

cs (mm)	c (mm)	
	$\alpha = 15^\circ \dots 20^\circ$	$\alpha = 20^\circ \dots 30^\circ$
4	3,5	2
5	4	2,5
6	4,5	3
7,5	5	4
10	6	5
12,5	8,5	6,5
15	10	7,5
20	13	10