

K09-N

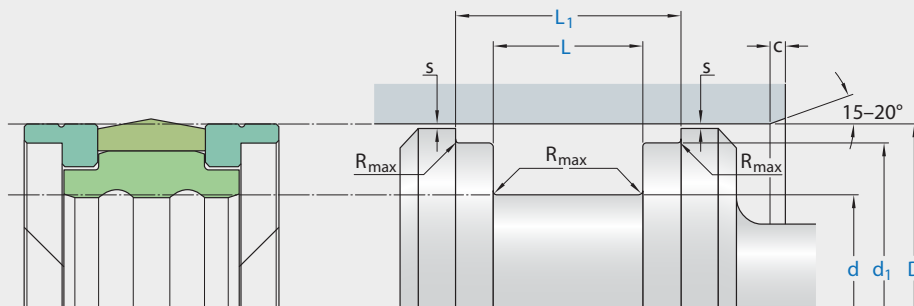

Ordering dimensions in blue

Surface roughness	R_{tmax}	R_a
Sliding surface	$\leq 2,5 \mu m$	$0,05-0,2 \mu m$
Bottom of groove	$\leq 6,3 \mu m$	$\leq 1,6 \mu m$
Groove face	$\leq 15 \mu m$	$\leq 3 \mu m$

Bearing area: 50-95% and a cutting depth of $0,5 R_z$, based on $C_{ref} = 0\%$

Standard dimensions		d	d_1	L	L_1	R_{max}	c	s^*
D	H9	d	d_1	L	L_1	R_{max}	c	s^*
over	incl.	h9	h8	+ 0,2				
mm								
20	50	D - 10	D - 3	12,5	20,5	0,4	4	0,35
50	80	D - 15	D - 4	20	28	0,4	5	0,52
80	150	D - 20	D - 5	25	36	0,4	6	0,65
150	400	D - 25	D - 6	32	46	0,4	8,5	0,78
400	600	D - 30	D - 8	36	50	0,4	10	1,00

* Extrusion gap values shown above are valid for a temperature of 70 °C, higher temperatures require lower values.

application



not bolded symbols; please consult our technical for application limitations

operating parameters & material

diameter range: up to 600 mm

sealing element	material		temperature	max. surface speed	max. pressure ¹	hydrolysis	dry running	wear resistance
	energizer	back-up ring						
ECOPUR	Ecorubber 1	Ecotal/Ecomid ²	-30 °C ... +100 °C	0,5 m/s	400 bar (40 MPa)	-	+	+
H-ECOPUR	Ecorubber 1	Ecotal/Ecomid ²	-20 °C ... +100 °C	0,5 m/s	400 bar (40 MPa)	-	+	+
T-ECOPUR	Ecorubber 1	Ecotal/Ecomid ²	-30 °C ... +100 °C	0,5 m/s	400 bar (40 MPa)	-	+	+
S-ECOPUR	Ecorubber 1	Ecotal/Ecomid ²	-20 °C ... +100 °C	0,7 m/s	400 bar (40 MPa)	-	+	+
G-ECOPUR	Ecorubber 1	Ecotal/Ecomid ²	-30 °C ... +100 °C	0,5 m/s	400 bar (40 MPa)	-	+	+

the stated operation conditions represent general indications. it is recommended not to use all maximum values simultaneously. surface speed limits apply only to the presence of adequate lubrication film.

¹ pressure ratings are dependent on the size of the extrusion gap.

² Ecotal up to ø260 mm, Ecomid above ø260 mm.

++ ... particularly suitable

o ... conditional suitable

+ ... suitable

- ... not suitable

for detailed information regarding chemical resistance please refer to our „list of resistance“. for increased chemical and thermal resistance resp. for higher gliding speeds PTFE-materials should be used (e.g. profile K09-F or a different sealing system).

note on special material:

other materials such as Viton, Silicone, EPDM, H-NBR, etc., can be used for the preload element, but they are only useful in specific cases (temperature or chemical influences). the temperature limits are determined by the guide- and support parts, using special materials can expand the temperature limits.

mode of installation

first of all the preload element should be slipped over the piston and snapped into the groove, then the first guiding- and backup element should be placed into the groove, followed by the gliding part and then the second guiding- and backup element. the installation of the guiding-and backup elements as well as the gliding part is generally trouble-free.

recommended mounting space:

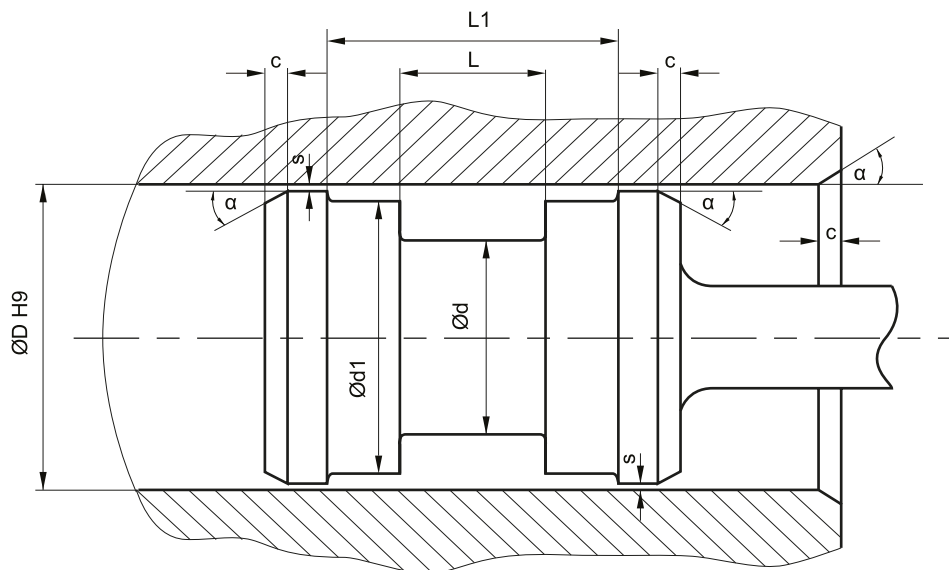

insertion chamfer:

in order to avoid damage to the piston seal during installation, the piston and the housing is to be chamfered and rounded as shown in the "recommended mounting space" drawing. the size of chamfer depends on the seal type and profile width.

cs (mm)	c (mm)	
	α = 15° ... 20°	α = 20° ... 30°
5	4	2,5
7,5	5	4
10	6	5
12,5	8,5	6,5
15	10	7,5
20	13	10

instead of a chamfer, the piston can also be designed with a radius. recommended size of the radius is equal to size of chamfer (R=c)