

K02-PD

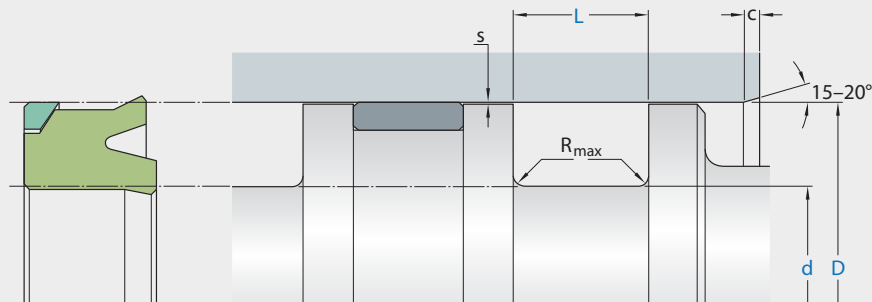

Ordering dimensions in blue

Surface roughness	R_{tmax}	R_a
Sliding surface	$\leq 2,5 \mu m$	$0,05-0,2 \mu m$
Bottom of groove	$\leq 6,3 \mu m$	$\leq 1,6 \mu m$
Groove face	$\leq 15 \mu m$	$\leq 3 \mu m$

Bearing area: 50-95% and a cutting depth of $0,5 R_z$, based on $C_{ref} = 0\%$

Standard dimensions						Maximal radial extrusion gap			
D	H9	d	L	R_{max}	c	s^*			
over	incl.	h10	+0,2			20 bar	100 bar	400 bar	700 bar
mm						mm			
13	25	D-8	6,0	0,4	3,5	0,80	0,80	0,30	0,04
25	50	D-10	7,0	0,4	4,0	1,00	1,00	0,37	0,04
50	75	D-12	8,0	0,4	4,5	1,25	1,24	0,42	0,05
75	150	D-15	10,0	0,4	5,0	1,50	1,47	0,46	0,05
150	300	D-20	12,0	0,4	6,0	2,00	1,77	0,54	0,06
300	500	D-25	18,0	0,4	8,5	2,5	2,06	0,62	0,06
500	750	D-30	20,0	0,4	10,0	3,00	2,43	0,76	0,06
750		D-40	26,0	0,4	13,0	3,00	2,43	0,76	0,06

application



not bolded symbols; please consult our technical for application limitations

* Extrusion gap values shown above are valid for a temperature of 70 °C, higher temperatures require lower values.

operating parameters & material

diameter range: up to 600 mm

material		temperature	max. surface speed	max. pressure ¹	hydrolysis	dry running	wear resistance
sealing element	back-up ring						
ECOPUR	Ecotal/Ecomid ²	-30 °C ... +100 °C	0,5 m/s	700 bar (70 MPa)	-	+	+
H-ECOPUR	Ecotal/Ecomid ²	-20 °C ... +100 °C	0,5 m/s	700 bar (70 MPa)	+	+	+
S-ECOPUR	Ecotal/Ecomid ²	-20 °C ... +100 °C	0,7 m/s	700 bar (70 MPa)	+	+	+
T-ECOPUR	Ecotal/Ecomid ²	-50 °C ... +100 °C	0,5 m/s	700 bar (70 MPa)	-	+	+
G-ECOPUR	Ecotal/Ecomid ²	-30 °C ... +100 °C	0,5 m/s	700 bar (70 MPa)	+	+	+

the stated operation conditions represent general indications. it is recommended not to use all maximum values simultaneously.

surface speed limits apply only to the presence of adequate lubrication film.

¹ pressure ratings are dependent on the size of the extrusion gap.

² Ecotal up to ø260 mm, Ecomid above ø260 mm.

note on special material:

as the temperature limits are determined by POM, using special materials for the back up ring can expand the temperature limits.

++ ... particularly suitable

o ... conditional suitable

+ ... suitable

- ... not suitable

for detailed information regarding chemical resistance please refer to our „list of resistance“. for increased chemical and thermal resistance rubber materials are to be preferred, attention should be paid to restrictions for pressure range and wear resistance. for higher gliding speeds another system should be used (e.g. PTFE materials).

note on special material:

as the temperature limits are determined by POM, using special materials for the back up ring can expand the temperature limits.

mode of installation

for inside diameters of 40mm and more, the seal can generally be slipped over the piston and snapped into closed grooves. due to occurring deformation force at installation, assembly aid tools are to be used for large cross-sections. the material deformation should not exceed the value of 20%, otherwise the permanent deformation would be too large.

recommended mounting space:

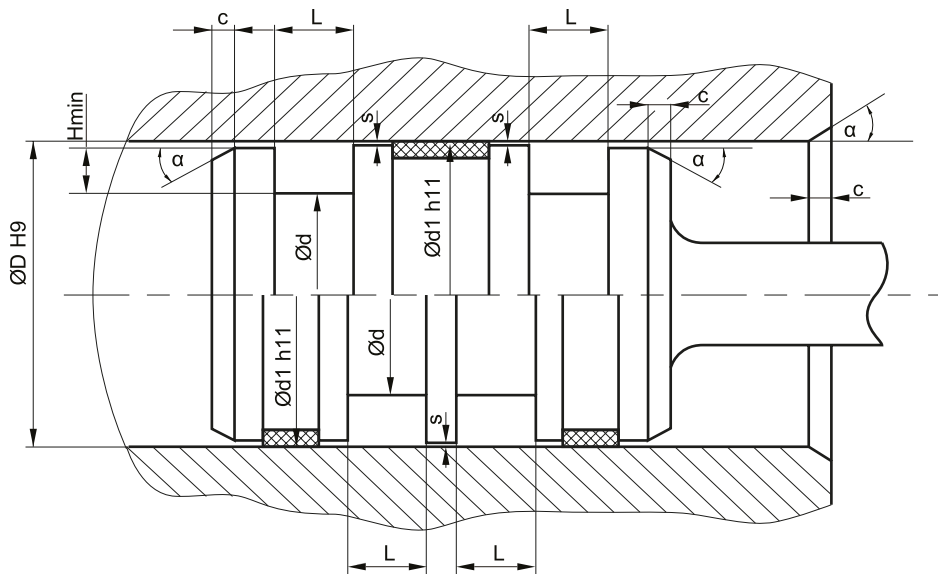

plastic guiderings (wearbands) have to feature a adequate cutting gap (recommendation: 2-5% of D). if metallic guides are used, spiral grooves shall be provided. smaller values for Hmin will ease the installation (reduced elongation and mounting force) but the height of the retaining collar has to be sufficient to assure a stable fit in the housing (larger than cs/2, smaller retaining collars will increase the danger of eversion of the profile in case of occurring drag pressure).

in order to avoid drag pressure built up in case of back-to-back arrangement, the distance between the seals should be as small as possible

insertion chamfer:

in order to avoid damage to the piston seal during installation, the piston and the housing is to be chamfered and rounded as shown in the "recommended mounting space" drawing. the size of chamfer depends on the seal type and profile width.

cs (mm)	c (mm)	
	$\alpha = 15^\circ \dots 20^\circ$	$\alpha = 20^\circ \dots 30^\circ$
4	3,5	2
5	4	2,5
6	4,5	3
7,5	5	4
10	6	5
12,5	8,5	6,5
15	10	7,5
20	13	10

instead of a chamfer, the piston can also be designed with a radius. recommended size of the radius is equal to size of chamfer (R=c).