

## F03

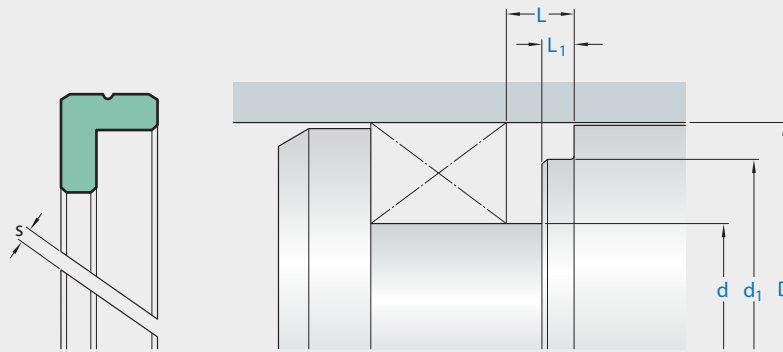

Ordering dimensions in **blue**

Sealing material Surface roughness	TPU / Elastomers		PTFE	
	$R_{tmax}$	$R_a$	$R_{tmax}$	$R_a$
	m		m	
Sliding surface	$\leq 2,5$	0,05–0,3	$\leq 2$	0,05–0,2
Bottom of groove	$\leq 6,3$	$\leq 1,6$	$\leq 6,3$	$\leq 1,6$
Groove face	$\leq 15$	$\leq 3$	$\leq 15$	$\leq 3$

Bearing area: 50–95% and a cutting depth of  $0,5 R_z$  based on  $C_{ref} = 0\%$

### application



*not bolded symbols; please consult our technical for application limitations*

### Standard dimensions

D	H9	d <sup>1)</sup>	d <sub>1</sub>	L	L <sub>1</sub>
over	incl.	h10	h8	+ 0,2	+ 0,2
mm					
20	50	D – 10	D – 3	6,5	4
50	80	D – 15	D – 4	8	4
80	150	D – 20	D – 5	10,5	5,5
150	400	D – 25	D – 6	13,4	7
400	750	D – 30	D – 8	14,2	7
750		D – 40	D – 8	15	7

Basic version: with a cutting gap  $s > 0$  allow no supporting function. For supporting function a cutting gap  $s = 0$  and a spiral groove is used.

<sup>1)</sup> Cross section usually depends on the seal profile. Cutting gap  $s \uparrow$  values depend on material and temperature. For detailed information please refer to the profile description.

## operating parameters & material

diameter range: up to 600 mm

material	temperature	max. surface speed	max. specific load
Ecotal <sup>2</sup>	-50 °C ... +100 °C	4,0 m/s	25 N/mm <sup>2</sup>
Ecomid <sup>2</sup>	-40 °C ... +100 °C	4,0 m/s	25 N/mm <sup>2</sup>
Ecoflon 2	-200 °C ... +200 °C	4,0 m/s	3 N/mm <sup>2</sup>
Ecoflon 3	-200 °C ... +200 °C	5,0 m/s	4,5 N/mm <sup>2</sup>
TEX	-40 °C ... +130 °C	1,0 m/s	90 N/mm <sup>2</sup>

the stated operation conditions represent general indications. it is recommended not to use all maximum values simultaneously. surface speed limits apply only to the presence of adequate lubrication film.

<sup>2</sup> Ecotal up to  $\varnothing 260$  mm, Ecomid above  $\varnothing 260$  mm.

## seal & housing recommendations

please note that we are able to produce those profiles to your specific need or any non standard housing. for detail measurements, please see seal-mart catalog...

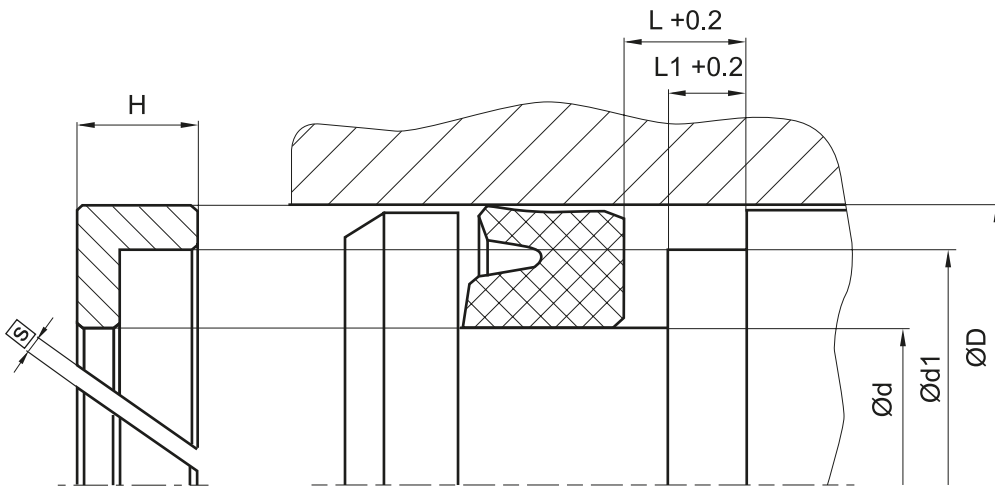

variations:

- cutting gap width  $s = \dots \text{mm}$
- endless

don't hesitate to contact our technical department for further information or for special requirements (temperature, speed etc.), so that suitable materials and/or designs can be recommended.