

A25-F

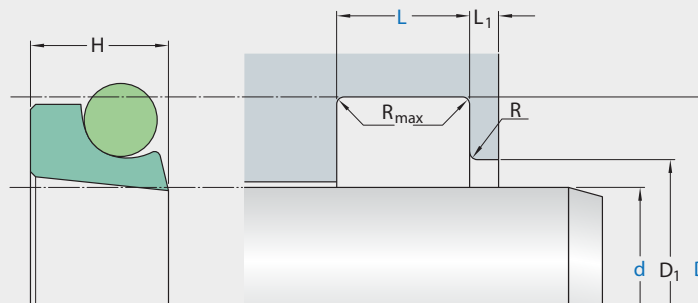

Ordering dimensions in blue

Surface roughness	TPU		PTFE	
	R_{tmax}	R_a	R_{tmax}	R_a
	m		m	
Sliding surface	$\leq 2,5$	$0,05-0,3 \mu m$	≤ 2	$0,05-0,2 \mu m$
Bottom of groove	$\leq 6,3$	$\leq 1,6$	$\leq 6,3$	$\leq 1,6$
Groove face	≤ 15	≤ 3	≤ 15	≤ 3

Bearing area: 50–95% and a cutting depth of $0,5 R_z$ based on $C_{ref} = 0\%$

Standard dimensions		D	OD	L	R_{max}	D_1	H
d	f8	H10		+0,2		H11	
over	incl.						
mm							
5	11	$d+4,8$	1,78	3,7	0,4	$d+2,7$	3,6
11	63	$d+6,8$	2,62	5,0	1,2	$d+3,5$	4,8
63	400	$d+8,8$	3,53	6,0	2,0	$d+4,0$	5,8
400	600	$d+12,2$	5,33	8,4	2,0	$d+6,0$	8,1

application



not bolded symbols; please consult our technical for application limitations

operating parameters & material

diameter range: up to 600 mm

material		temperature	max. surface speed	hydrolysis	dry running	wear resistance
sealing element	energizer					
Ecoflon 2	Ecorubber 1	-30 °C ... +100 °C	10 m/s	-	++	+
Ecoflon 2	Ecorubber 2	-20 °C ... +200 °C	10 m/s	-	++	+
Ecoflon 3	Ecorubber 1	-30 °C ... +100 °C	10 m/s	-	++	+
Ecoflon 3	Ecorubber 2	-20 °C ... +200 °C	10 m/s	-	++	+
Ecoflon 4	Ecorubber 1	-30 °C ... +100 °C	10 m/s	-	++	+
Ecoflon 4	Ecorubber 2	-20 °C ... +200 °C	10 m/s	-	++	+
X-ECOPUR	Ecorubber 1	-30 °C ... +110 °C	5 m/s			

the stated operation conditions represent general indications. it is recommended not to use all maximum values simultaneously.

surface speed limits apply only to the presence of adequate lubrication film.

++ ... particularly suitable o ... conditional suitable
 + ... suitable - ... not suitable

for detailed information regarding chemical resistance please refer to our "list of resistance". for increased chemical and thermal resistance rubber materials are to be preferred, polyurethan materials increase wear resistance.

surface quality

surface roughness	Rtmax (µm)	Ra (µm)
sliding surface	according to seal data	
bottom of groove	≤6,3	≤1,6
groove face	≤15	≤3

tolerance recommendation

seal housing tolerances	
L	+0,2
∅D	H9

mode of installation

the prerequisites for perfect functioning are careful fitting and an accurately dimensioned mounting space. in general, wipers snap easily into their housings when distorted into a kidney shape (over 20mm diameter). a large insertion chamfer must be provided (20-30°, length = (D-d)/4).