

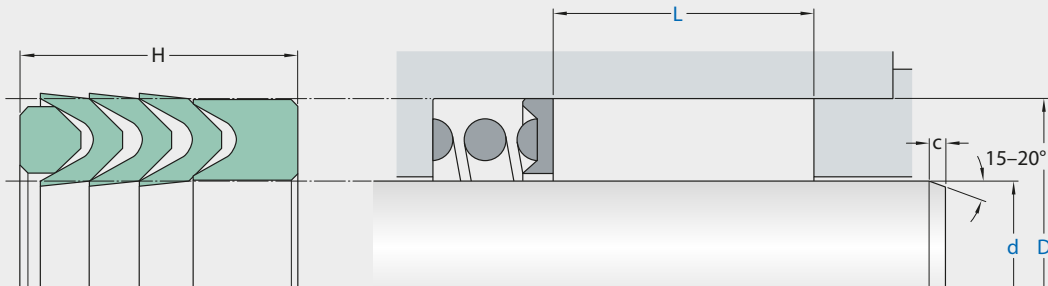

S2527-F



Ordering dimensions in blue

Surface roughness	R_{tmax}	R_a
Sliding surface	$\leq 2 \mu m$	0,05–0,3 μm
Bottom of groove	$\leq 6,3 \mu m$	$\leq 1,6 \mu m$
Groove face	$\leq 15 \mu m$	$\leq 3 \mu m$

Bearing area: 50–95% and a cutting depth of $0,5 R_z$ based on $C_{ref} = 0\%$

Standard dimensions			Installation height				
d	f8	D	c	L*	2 chevrons	3 chevrons	4 chevrons
over	incl.	H8		up to 16 bar	up to 50 bar	up to 100 bar	
mm				mm			
10	16	d + 8	3,5	12	15	18	
16	40	d + 10	4,0	14	19	23	
40	50	d + 12	4,5	16	22	26	
50	75	d + 15	5	19	27	33	
75	150	d + 20	6	25	35	42	
150	200	d + 25	8,5	32	44	53	
200	300	d + 30	10	39	54	64	
300		d + 40	13	45	64	76	

application



not bolded symbols; please consult our technical for application limitations

* The recommended chevron height depends on the pressure area and is valid for SKF Ecoflon 1. Installation height L = chevron set height H. Standard: 3 chevrons

operating parameters & material

diameter range: up to 600 mm

material			temperature	max. surface speed	max. pressure ¹	hydrolysis	dry running	wear resistance
header ring S25-F	sealing element S26-F	back-up ring S27-F						
Ecoflon 2	Ecoflon 1	Ecoflon 2	-200 °C ... +260 °C	1,5 m/s	100 bar (10 MPa)	++	++	O

the stated operation conditions represent general indications. it is recommended not to use all maximum values simultaneously.

surface speed limits apply only to the presence of adequate lubrication film.

¹ pressure ratings are dependent on the size of the extrusion gap.

++ ... particularly suitable

o ... conditional suitable

+ ... suitable

- ... not suitable

for detailed information regarding chemical resistance please refer to our "list of resistance". for decreased leakage rates elastomer materials (polyurethane or rubber) in other sealing systems are to be preferred.

mode of installation

at first insert spring into housing. as far as possible, a metallic plate should be placed between spring and seal set in order to ensure a evenly distributed contact pressure. afterwards insert the male ring, then the packing and finally the pressure ring (well greased) into the installation space. insert the metal insert without load, complete mounting of the system, tighten metal inserts slightly, let run in (10 to 20 idle strokes). finally tighten the metal insert to nominal height.

recommended mounting space:

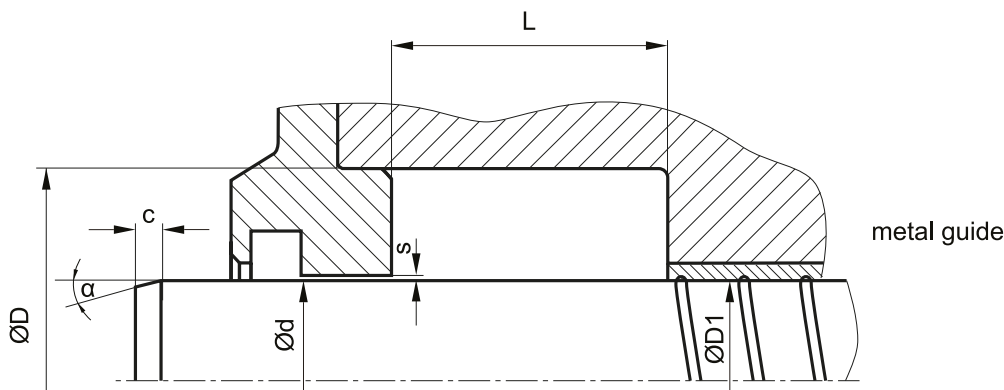

recommended guide tolerance D1:

d f8 [mm]	p ≤ 100 [bar]
≤ 100	H9
> 100 ≤ 200	H8
> 200	H8

insertion chamfer:

in order to avoid damage to the rod seal during installation, the piston rod is to be chamfered and rounded as shown in the "recommended mounting space" drawing. the size of chamfer depends on the seal type and profile width.

cs (mm)	c (mm)	
	α = 15° ... 20°	α = 20° ... 30°
4	3,5	2
5	4	2,5
6	4,5	3
7,5	5	4
10	6	5
12,5	8,5	6,5
15	10	7,5
20	13	10