

# S18-R

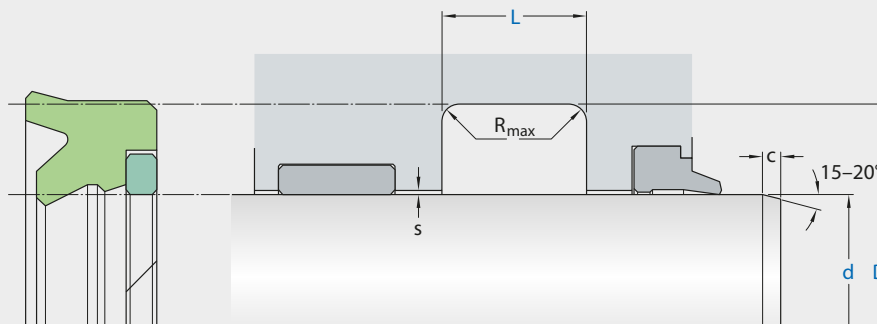

Ordering dimensions in blue

Surface roughness	$R_{tmax}$	$R_a$
Sliding surface	$\leq 2,5 \mu m$	$0,1-0,5 \mu m$
Bottom of groove	$\leq 6,3 \mu m$	$\leq 1,6 \mu m$
Groove face	$\leq 15 \mu m$	$\leq 3 \mu m$

Bearing area: 50-95% and a cutting depth of  $0,5 R_z$  based on  $C_{ref} = 0\%$

Standard dimensions						maximal radial extrusion gap $s^*$		
d	f8	D	L	$R_{max}$	c	20 bar	100 bar	250 bar
over	incl.	H10	+ 0,2					
mm						mm		
23	25	d + 8	8,0	0,4	3,5	0,60	0,80	0,52
25	50	d + 10	9,0	0,4	4,0	1,00	1,00	0,66
50	150	d + 15	14,0	0,4	5,0	1,50	1,40	0,78
150	300	d + 20	17,0	0,4	6,0	2,00	1,66	0,88
300	500	d + 25	20,0	0,4	8,5	2,50	1,91	1,00
500	600	d + 30	25,0	0,4	10,0	3,00	2,18	1,13

\* Extrusion gap values shown above are valid for a temperature of 70 °C, higher temperatures require lower values.

## application



not bolded symbols; please consult our technical for application limitations

## operating parameters & material

diameter range: up to 600 mm

material		temperature	max. surface speed	max. pressure <sup>1</sup>	hydrolysis	dry running	wear resistance
sealing element	back-up ring						
Ecorubber 1	Ecotal <sup>2</sup>	-30 °C ... +100 °C	0,5 m/s	250 bar (25 MPa)	-	-	O
Ecorubber 1	Ecomid <sup>2</sup>	-30 °C ... +100 °C	0,5 m/s	250 bar (25 MPa)	-	-	O
Ecorubber 2	Ecoflon 2	-20 °C ... +200 °C	0,5 m/s	250 bar (25 MPa)	-	-	O
Ecorubber 3 <sup>3</sup>	Ecotal <sup>2</sup>	-50 °C ... +100 °C	0,5 m/s	250 bar (25 MPa)	++	-	O
Ecorubber 3 <sup>3</sup>	Ecomid <sup>2</sup>	-50 °C ... +100 °C	0,5 m/s	250 bar (25 MPa)	+	-	O
Ecorubber 3 <sup>3</sup>	Ecoflon 2	-50 °C ... +150 °C	0,5 m/s	250 bar (25 MPa)	++	-	O
Ecorubber H	Ecotal <sup>2</sup>	-25 °C ... +100 °C	0,5 m/s	250 bar (25 MPa)	+	O	+
Ecorubber H	Ecomid <sup>2</sup>	-25 °C ... +100 °C	0,5 m/s	250 bar (25 MPa)	+	O	+
Ecorubber H	Ecoflon 2	-25 °C ... +150 °C	0,5 m/s	250 bar (25 MPa)	+	O	+

the stated operation conditions represent general indications. it is recommended not to use all maximum values simultaneously. surface speed limits apply only to the presence of adequate lubrication film.

<sup>1</sup> pressure ratings are dependent on the size of the extrusion gap.

<sup>2</sup> Ecotal up to ø260 mm, Ecomid above ø260 mm.

<sup>3</sup> attention: not suitable for mineral oils!

++ ... particularly suitable

o ... conditional suitable

+ ... suitable

- ... not suitable

for detailed information regarding chemical resistance please refer to our „list of resistance“. for increased wear resistance and higher pressure range polyurethane materials are to be preferred, attention should be paid to restrictions in chemical and thermal resistance. for higher gliding speeds another sealing system should be used (e.g. PTFE materials).

note on special materials:

as the temperature limits are determined by POM using special materials for the back up ring can expand the temperature limits.

### recommended mounting space:

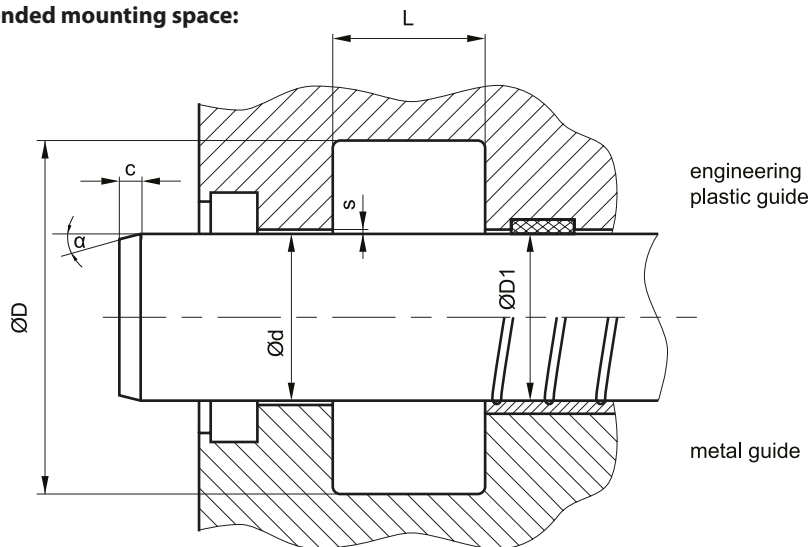

### recommended guide tolerance D1:

d f8 [mm]	p ≤ 100 [bar]	100 < p ≤ 200 [bar]	p > 200 [bar]
≤ 100	H10	H8	H8
> 100 ≤ 200	H10	H8	H7
>200	H9	H8	H7

### insertion chamfer:

in order to avoid damage to the rod seal during installation, the piston rod is to be chamfered and rounded as shown in the "recommended mounting space" drawing. the size of chamfer depends on the seal type and profile width.

cs (mm)	c (mm)	
	α = 15° ... 20°	α = 20° ... 30°
4	3,5	2
5	4	2,5
6	4,5	3
8	5	4
10	6	5
12,5	8,5	6,5
15	10	7,5
20	13	10