

# S01-P

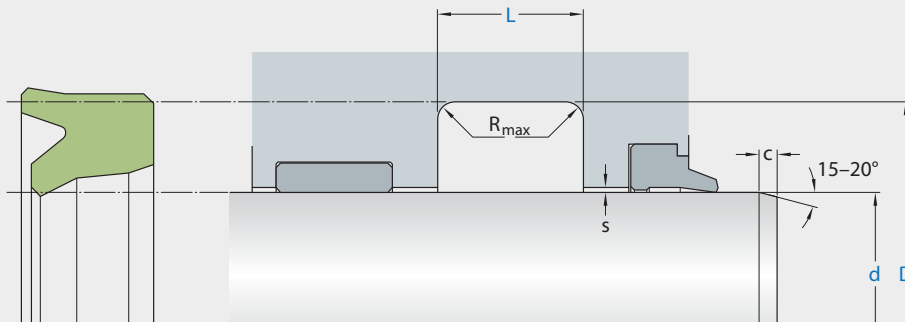

Ordering dimensions in blue

Surface roughness	$R_{tmax}$	$R_a$
Sliding surface	$\leq 2,5 \mu m$	$0,05-0,3 \mu m$
Bottom of groove	$\leq 6,3 \mu m$	$\leq 1,6 \mu m$
Groove face	$\leq 15 \mu m$	$\leq 3 \mu m$

Bearing area: 50-95% and a cutting depth of  $0,5 R_z$  based on  $C_{ref} = 0\%$

Standard dimensions		D H10	L +0,2	$R_{max}$	c	Maximal radial extrusion gap $s^*$			
d f8 over	incl.					20 bar	100 bar	200 bar	400 bar
mm		mm							
11	25	d + 8	6,3	0,4	3,5	0,33	0,17	0,11	0,05
25	50	d + 10	8,0	0,4	4,0	0,37	0,22	0,16	0,10
50	150	d + 15	10,0	0,4	5,0	0,46	0,31	0,25	0,19
150	300	d + 20	14,0	0,4	6,0	0,54	0,39	0,32	0,26
300	500	d + 25	17,0	0,4	8,5	0,61	0,46	0,39	0,33
500	700	d + 30	25,0	0,4	10,0	0,67	0,52	0,45	0,39
700		d + 40	32,0	0,4	13,0	0,67	0,52	0,45	0,39

## application



*not bolded symbols; please consult our technical for application limitations*

\* Extrusion gap values shown above are valid for a temperature of 70 °C, higher temperatures require lower values.

## operating parameters & material

diameter range: up to 600 mm

material	temperature	max. surface speed	max. pressure <sup>1</sup>	hydrolysis	dry running	wear resistance
ECOPUR	-30 °C ... +110 °C	0,5 m/s	400 bar (40 MPa)	-	+	++
H-ECOPUR	-20 °C ... +110 °C	0,5 m/s	400 bar (40 MPa)	++	+	++
T-ECOPUR	-50 °C ... +110 °C	0,5 m/s	400 bar (40 MPa)	-	+	++
S-ECOPUR	-20 °C ... +110 °C	0,7 m/s	400 bar (40 MPa)	++	++	++
G-ECOPUR	-30 °C ... +110 °C	0,5 m/s	400 bar (40 MPa)	++	+	++

the stated operation conditions represent general indications. it is recommended not to use all maximum values simultaneously. surface speed limits apply only to the presence of adequate lubrication film.

<sup>1</sup> pressure ratings are dependent on the size of the extrusion gap.

++ ... particularly suitable

o ... conditional suitable

+ ... suitable

- ... not suitable

for detailed information regarding chemical resistance please refer to our „list of resistance“. for increased chemical and thermal resistance rubber materials are to be preferred, attention should be paid to restrictions for pressure range and wear resistance. for higher gliding speeds another system should be used (e.g. PTFE materials).

## mode of installation

for inside diameters of 25mm or more, and dependant on radial cross section (cs), seals may be snapped into closed housings.

Ød	type of installation
≤ 6•cs	open mounting space required
> 6•cs ..... ≤ 10•cs	snap mounting with tool
> 10•cs	snap mounting by hand

## recommended mounting space:

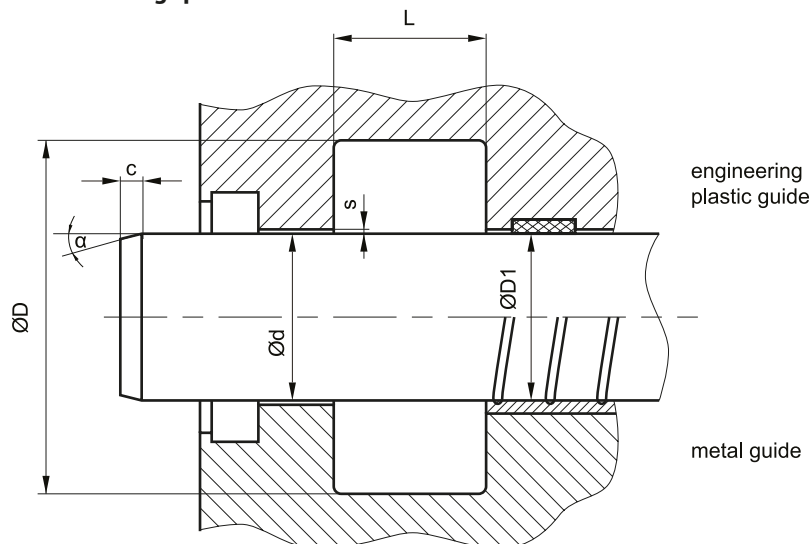

## recommended guide tolerance D1:

d f8 [mm]	$p \leq 100$ [bar]	$100 < p \leq 200$ [bar]	$p > 200$ [bar]	secondary seal
≤ 100	H10	H8	H8	H8
> 100 ≤ 200	H10	H8	H7	H8
> 200	H9	H8	H7	H8

## insertion chamfer:

in order to avoid damage to the rod seal during installation, the piston rod is to be chamfered and rounded as shown in the "recommended mounting space" drawing. the size of chamfer depends on the seal type and profile width.

cs (mm)	c (mm)	
	$\alpha = 15^\circ \dots 20^\circ$	$\alpha = 20^\circ \dots 30^\circ$
(2)	2	1
(3)	3	1,5
4	3,5	2
5	4	2,5
6	4,5	3
7,5	5	4
10	6	5
12,5	8,5	6,5
15	10	7,5
20	13	10