

K03-S

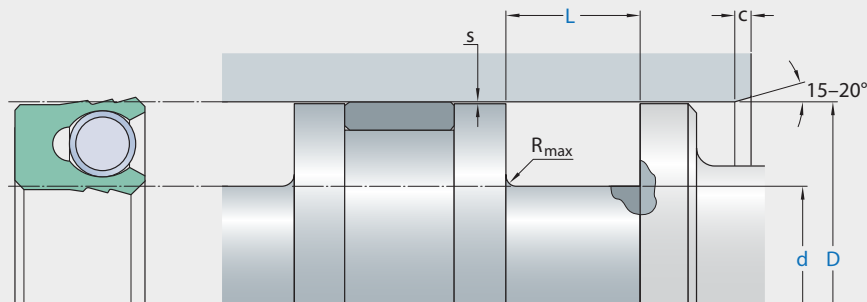

Ordering dimensions in blue

Surface roughness	R_{tmax}	R_a
Sliding surface	$\leq 2 \mu m$	$0,05-0,2 \mu m$
Bottom of groove	$\leq 6,3 \mu m$	$\leq 1,6 \mu m$
Groove face	$\leq 15 \mu m$	$\leq 3 \mu m$

Bearing area: 50-95% and a cutting depth of $0,5 R_z$, based on $C_{ref} = 0\%$

Standard dimensions						Maximal radial extrusion gap			
D	H9	d	L	R_{max}	c	s^*			
over	incl.	h10	+0,2			20 bar	100 bar	200 bar	400 bar
mm						mm			
9	15	D-4	3,5	0,4	2,0	0,25	0,12	0,10	0,07
15	30	D-6	5,0	0,4	3,0	0,35	0,17	0,12	0,08
30	120	D-10	8,0	0,4	4,0	0,45	0,22	0,17	0,10
120	200	D-15	11,5	0,4	5,0	0,75	0,40	0,33	0,18
200	250	D-20	13,0	0,4	6,0	0,87	0,48	0,38	0,20
250	500	D-25	18,5	0,4	8,5	0,87	0,48	0,38	0,20
500	1600	D-30	23,0	0,4	10,0	0,87	0,48	0,38	0,20

application



not bolded symbols; please consult our technical for application limitations

* Extrusion gap values shown above are valid for a temperature of 70 °C, higher temperatures require lower values.

operating parameters & material

diameter range: up to 600 mm

material		temperature	max. surface speed	max. pressure ¹	hydrolysis	dry running	wear resistance
sealing element	energizer (spring)						
Ecoflon 1	spring (1.4310)	-200 °C ... +260 °C	1,0 m/s	100 bar (10 MPa)	++	++	O
Ecoflon 2	spring (1.4310)	-200 °C ... +260 °C	1,0 m/s	160 bar (16 MPa)	++	++	+
Ecowear	spring (1.4310)	-200 °C ... +80 °C	0,5 m/s	200 bar (20 MPa)	++	+	+

the stated operation conditions represent general indications. it is recommended not to use all maximum values simultaneously. surface speed limits apply only to the presence of adequate lubrication film.

¹ pressure ratings are dependent on the size of the extrusion gap.

++ ... particularly suitable

o ... conditional suitable

+ ... suitable

- ... not suitable

for detailed information regarding chemical resistance please refer to our "list of resistance". for decreased leakage rates elastomer materials (polyurethane or rubber) in other sealing systems are to be preferred.

mode of installation

open housings are required.

recommended mounting space:

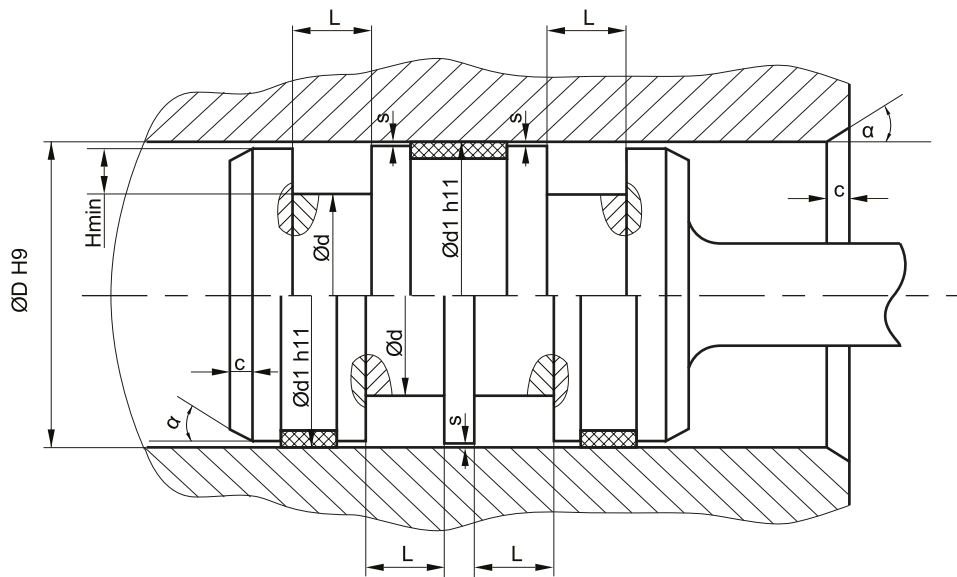

plastic guiderings (wearbands) have to feature a adequate cutting gap (recommendation: 2-5% of D). if metallic guides are used, spiral grooves shall be provided. the height of the retaining collar has to be sufficient to assure a stable fit in the housing (larger than $cs/2$, smaller retaining collars will increase the danger of eversion of the profile in case of occuring drag pressure).

in order to avoid drag pressure built up in case of back-to-back arrangement, the distance between the seals should be as small as possible.

insertion chamfer:

in order to avoid damage to the piston seal during installation, the piston and the housing is to be chamfered and rounded as shown in the "recommended mounting space" drawing. the size of chamfer depends on the seal type and profile width.

cs (mm)	c (mm)	
	$\alpha = 15^\circ \dots 20^\circ$	$\alpha = 20^\circ \dots 30^\circ$
2	2	1
3	3	1,5
4	3,5	2
5	4	2,5
6	4,5	3
7,5	5	4
10	6	5
12,5	8,5	6,5
15	10	7,5
20	13	10

instead of a chamfer, the piston can also be designed with a radius. recommended size of the radius is equal to size of chamfer ($R=c$).