

ST10

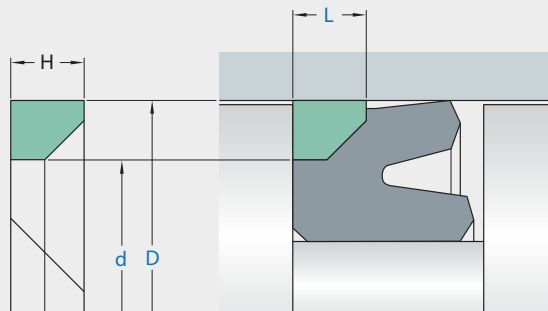

Ordering dimensions in blue

Sealing material	TPU / Elastomers / PTFE	
Surface roughness	R_{tmax}	R_a
	m	
Sliding surface	$\leq 2,5$	0,05–0,2
Bottom of groove	$\leq 6,3$	$\leq 1,6$
Groove face	≤ 15	≤ 3

Bearing area: 50–95% and a cutting depth of 0,5 R_z based on $C_{ref} = 0\%$

Standard dimensions

Minimum nominal inside diameter
 $d \geq 4,5 \text{ mm}$.

Profile size, surface data and tolerances are the result of a combination of the relevant application specific sealing material. Standard version: cutting gap 0, cut 45°.

application



operating parameters & material

diameter range: up to 600 mm

material	temperature
Ecotal ²	-50 °C ... +100 °C
Ecomid ²	-40 °C ... +100 °C
Ecoflon 2	-200 °C ... +260 °C

the stated operation conditions represent general indications. it is recommended not to use all maximum values simultaneously. surface speed limits apply only to the presence of adequate lubrication film.

² Ecotal up to ø260 mm, Ecomid above ø260 mm.

seal & housing recommendations

please note that we are able to produce those profiles to your specific need or any non standard housing. for detail measurements, please see seal-mart catalog...

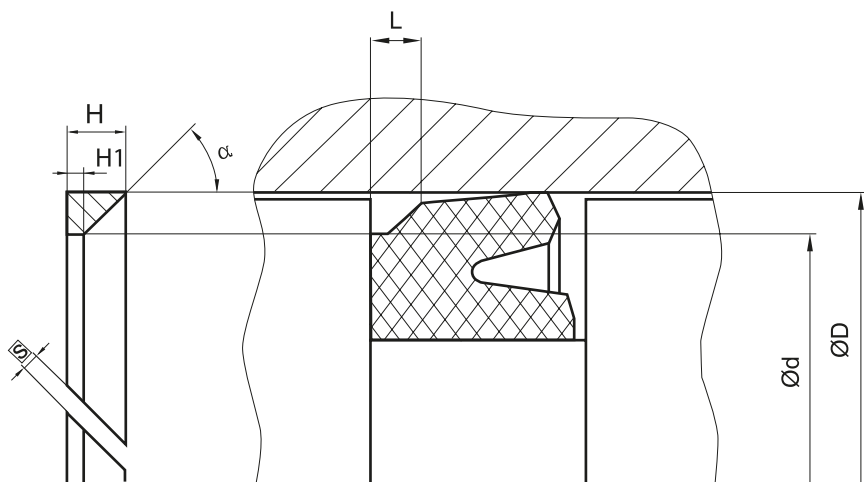

variations:

- cutting gap width $s=0\text{mm}$
- endless

tolerance value and surface finish according to corresponding seal data sheet

don't hesitate to contact our technical department for further information or for special requirements (temperature, speed etc.), so that suitable materials and/or designs can be recommended.